

Marine generator set

Quiet Gasoline™ Series

8 QG 60 Hz

Model MGKBD



Cummins Onan

Performance you rely on.™



Features and benefits

- Rugged dependability, high quality and innovation make Cummins Onan Marine Generators the leader in marine generator design and development, providing performance you rely on.™
- The digital QD (Quiet Diesel) Series models are the first marine generator sets with self-monitoring capability and network communication.
- The optional Cummins Onan Digital Display provides user-friendly diagnostics including extensive engine and alternator information, self-diagnostic features and text display.
- The Cummins Onan Marine Generators with advanced design and development processes use technology to lower sound and vibration. Our sound shields minimize noise and deliver better sound quality. The optimized mounting system greatly reduces vibration.
- Certified to U.S. Environmental Protection Agency (EPA) and California Air Resources Board (CARB) emission standards.
- Cummins Onan Marine Generators have the largest worldwide certified distributor/dealer support network in the industry with more than 70 years of experience.

Models and ratings

Model	kVA/kW	Voltage	Amps	Phase	Hz	Engine RPM
8.0MGKBD	8.0/8.0	120	66.7	1	60	2400
		120/240	66.7/33.3	1	60	2400

Single phase output at 1.0 power factor. Rating conditions are 100 kPa (29.6 in Hg) barometric pressure, 30% relative humidity and 25° C (77° F) (ref. ISO 3046).

Sound level, weight, and size

Sound level	Dimensions	Length	Width	Height
60 Hz configuration	Weight (dry)			
69 dB(A)*	193 kg (425 lb)	676 mm (26.6 in)	583 mm (23 in)	535 mm (21.1 in)

* Full load at 1 m

Standard features

- Advanced digital electronic control providing extensive diagnostic capability
- Shutdown with diagnostic indicator light for: high engine coolant temperature, high exhaust temperature, low oil pressure, over speed/voltage, starter overcrank, field current overload, CO monitor (not supplied with generator set), no raw water flow, additional customer input and many more
- Electronic governor allows the generator set to maintain isochronous frequency control and close voltage regulation to provide quality power for digital appliances and computers
- Oil level check and fill accessed from control panel outside integral enclosure
- Single phase AC alternator with single or dual voltages
- Digital voltage regulator integral with control
- Start-run-stop switch with fuel pump priming mode for easy starting; run light and diagnostic indicator light
- Electronic fuel transfer pump for priming and lift capability
- Engine starter with automatic start disconnect
- Freshwater cooling system with heat exchanger, expansion tank and coolant recovery system
- Water cooled exhaust mixing elbow
- AC mainline circuit breaker
- Running time meter
- Air intake silencer
- Full flow lube oil filter
- Oil drain valve and hose connection
- Electric fuel shut-off solenoid
- Fuel cooler for improved performance at high ambient temperatures
- Fuel filter
- Drip pan base capable of containing all generator set fluids
- Captive focalized mounting systems with vibration isolators
- External mount tabs allow flexible mounting arrangement
- Bulk head type connections for ease of installation include fuel in, battery, raw water inlet, exhaust, generator set ground (vessel bond)
- Integral enclosure for environmental protection
- Plug-in watertight connector for optional remote panel control
- Coolant over flow bottle to easily maintain coolant level
- Fire extinguisher access port
- Factory load tested
- Five year limited warranty

Engine details

Design: 4-cycle, water-cooled gasoline

Cylinders: 3

Bore: 68 mm (2.68 in)

Stroke: 68 mm (2.68 in)

Displacement: 740 cm³ (45.2 in³)

Compression ratio: 9.2:1

Max fuel lift: 1.2 m (4 ft)

Lube oil capacity: 2.1 L (2.2 qt)

Coolant capacity: 3.1 L (3.3 qt)

Coolant flow rate:

60 Hz: 13 L/min (3.5 Gal/min)

Raw water flow rate:

60 Hz: 19 L/min (5 Gal/min)

Starting system: 12 V

Power (max): SAEJ1349

60 Hz at 2400 RPM 13.8 kW (18.5 hp)

Max raw water lift: 1.2 m (4 ft)

Typical fuel consumption

Gasoline, L/hr (Gal/hr)	No load	1/4 load	1/2 load	3/4 load	Full load
8.0 MGKBD 60 Hz	1.3 (0.35)	1.9 (0.51)	2.9 (0.77)	3.9 (1.05)	5.3 (1.4)

Alternator details

Design: Cummins Onan revolving field, 2-pole drip-proof construction

Voltage regulator: Integral with the digital control

Stator: Skewed stator and 2/3 pitch windings minimize field heating and voltage harmonics; resin-coated for corrosion protection

Rotor: Dynamically balanced assembly; supported by pre-lubricated, maintenance-free ball bearings

Cooling: Rotor mounted centrifugal blower

Insulation system: Class H per NEMA MG1-1.65 and BS 5000

Generator set performance

Operating environment: Generator sets are durability tested at maximum ambient air temperature: 50° C (122° F); raw water temperature 37.8° C (100° F)

Frequency regulation: Isochronous

Random frequency variation: Will not exceed +/-0.5% of its mean value for constant loads from no load to full load

Voltage regulation: +/-1.5%

Basic dimensions

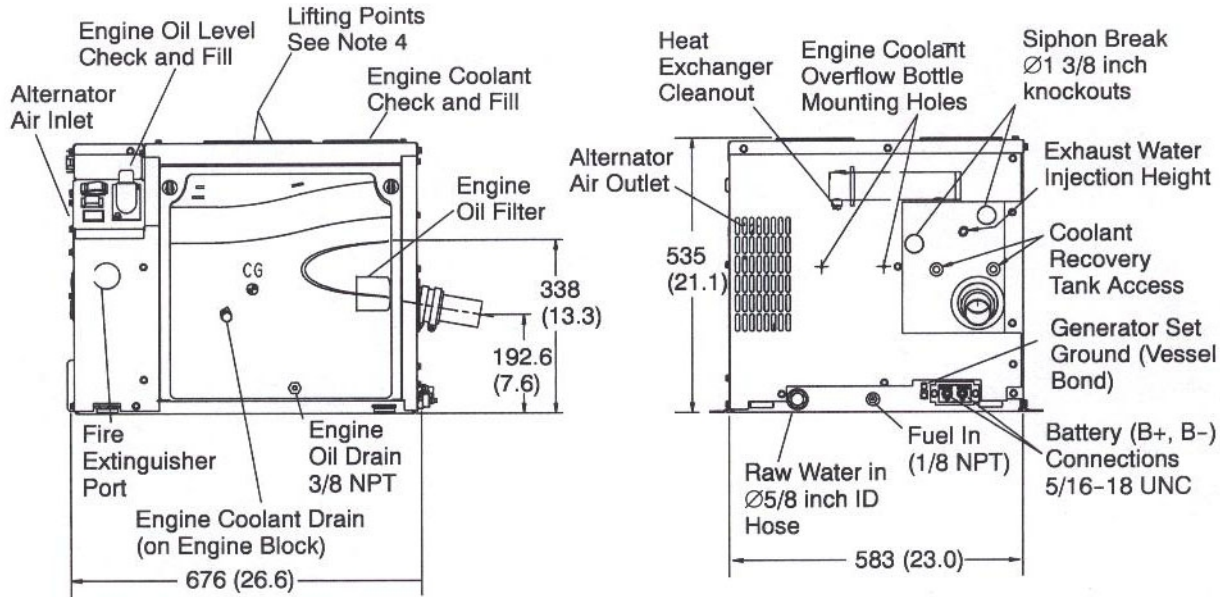

mm (in)

- 25.4 (1.00) minimum clearance required for airflow at air inlet and outlet
- 4 tabs (one at each corner) minimum required when using external mounting tabs
- Two point lift is required

Note: This outline drawing is provided for general reference only and is not intended for design or installation. For more information see Operation and Installation manuals or obtain drawing 500-3363 and wiring diagram from your distributor/dealer.

Options

- 3 amp (net) battery charging regulator
- SAE J-1939 CAN data link for monitoring generator set status and diagnostics for engine and alternator

SmartCraft Networked™ data link for monitoring generator set status and diagnostics for engine and alternator (display available through Cummins MerCruiser Diesel)

Accessories

- Cummins Onan Digital Display - graphical LCD remote display for generator set operating parameters and diagnostics
- Basic remote panel with start/stop switch with run (green) and control status (amber) lamps
- Deluxe remote panel with run (green) and control status (amber) lamps and voltmeter
- Remote station harness pigtail
- Remote panel wire harness - 15 ft, 25 ft, 45 ft, 75 ft, 100 ft or 150 ft
- Siphon break kit
- Wet exhaust hose and stainless steel elbow
- Battery
- Water lift muffler
- Ship to shore selector switch, single phase, 2 or 3 wire output

- Deluxe remote panel with start/stop switch with run (green) and control status (amber) lamps and hour meter
- Remote switch and harness (connection) only for customer panel
- Line circuit breakers for field conversion of AC voltage output
- Cruise kit - maintenance parts - fuel filters, oil filters, raw water pump impellers, raw water pump belt, spark plugs, oil filter wrench, and plastic container
- Bulkhead battery terminal boots



Cummins Onan Digital Display

Standards and testing

National Marine Manufacturers Association (NMMA) members produce every conceivable product used by recreational boaters. NMMA provides a wide variety of programs and services including technical expertise, standards monitoring, government relations advocacy and industry statistics.

The American Boat and Yacht Council (ABYC) develops standards and recommended practices for designing, constructing, equipping and maintaining small pleasure and commercial craft.

This generator set was designed and manufactured in facilities certified to ISO 9001.

This generator set complies with the fire test and the ignition protection requirements of the US Coast guard safety standards and ISO standards 10088 and 8846.



Warranty policy

The Cummins Onan express, written limited warranty covers virtually everything except routine maintenance for the first two years you own your marine generator set, and covers parts and labor on major power train and generator set parts during the third through fifth years.

Warning: Backfeed to a utility system can cause electrocution and/or property damage. Do not connect to any building electrical except through an approved device or after building main breaker is open.

After sale support

Largest distributor/dealer support network

Cummins Onan generator sets are supported by the largest and best trained worldwide certified distributor/dealer network in the industry. This network of knowledgeable Cummins Onan distributor/dealers will help you select and install the right generator set and accessories to meet the requirements of your specific application. This same network offers a complete selection of commonly used generator set maintenance parts, accessories and products plus manuals and specification sheets. Plus, they can answer your questions regarding proper operation, maintenance schedules and more.

Manuals: Operation and installation manuals ship with the generator set. To obtain additional copies or other manuals for this model, see your Cummins Onan distributor/dealer and request the following manual numbers: Operation (981-0537), Installation (981-0635), Parts (981-0274), Service (981-0537).

To easily locate the nearest Cummins Onan distributor/dealer in your area, or for more information, contact us at 1-800-888-6626 (or 763-574-5000), or visit www.cumminsonan.com.

Contact your distributor/dealer for more information

Cummins Onan

Cummins Power Generation

1400 73rd Ave. NE
Minneapolis, MN 55432 USA
Phone 1 763 574 5000
Toll-free 1 800 888 6626
Fax 1 763 574 5298
Email www.cumminsonan.com/contact
www.cumminsonan.com

