

Marine Generator Set

Engine Features

- Port fuel injected
- CARB/EPA Tier II emission compliant
- Electronic control module for optimizing fuel and spark performance
- Gasoline fueled
- Four cylinder
- Four cycle
- Pistons have high silicon content for improved durability and noise reduction
- Sintered powdered-metal exhaust valve seat inserts for enhanced durability
- Poly V-belt harmonic balancer
- Heat exchanger
- Electronic governing with frequency regulation of $\pm 1.2\%$
- Lifting eyes
- Electric fuel lift pump
- Closed cooling system
- Ultra low CO emissions

Generator Features

- Remote start 12-pin connector
- Class H insulation
- Voltage regulation of $\pm 1.5\%$
- RFI suppression

ADC 2100 Advanced Digital Control Features

- Designed for today's most sophisticated electronics
- Easy to read alpha-numeric display
- Compact, integrally mounted control
- Potted boards/sealed connectors for maximum corrosion protection
- SAE J1939 CANbus output
- Remote monitoring of up to 14 fault conditions
- Membrane keypad for configuration and adjustment
- Programmed crank cycle
- CO sensor module

Optional Accessories

- Remote digital gauge
- Ship-to-shore transfer switch
- Siphon break

Generator Weights and Dimensions

Weight, kg (lbs.) Wet	245 (540)
Length, mm (in.)	974 (38.34)
Width, mm (in.)	527 (20.76)
Height, mm (in.)	671 (26.40)

See the drawings on the last page for the detailed dimensions.

Generator Ratings

Model Series	Voltage	Hz	25°C (77°F) Amps	25°C (77°F) kW/kVA
13EGD	120/240	60	54.1*	13.0/13.0
11EFGD	230	50	47.8	11.0/11.0

* Denotes amps per terminal.

RATINGS: Marine continuous ratings per ISO 3046, ISO 8528-1, and Kohler ISO rating guideline 2.14. Obtain technical information bulletin (TIB-101) on ratings guidelines for complete ratings definitions.

Availability is subject to change without notice. Kohler Co. reserves the right to change the design or specifications without notice and without any obligation or liability whatsoever. Contact your local Kohler generator distributor for availability.

Application Data

Engine

Engine Specifications	60 Hz	50 Hz
Type	4 Cycle	
Cylinders, number	4	
Displacement, L (CID)	1.6 (98)	
Bore and stroke, mm (in.)	79 (3.11) x 81.5 (3.21)	
Compression ratio	9.4:1	
Rated rpm	1800	1500
Max. power at rated rpm, HP	24.5	18.5
Cylinder block material	Cast iron	
Cylinder head material	Aluminum	
Crankshaft material	Cast iron	
Piston rings	2 compression/1 oil control	
Crankshaft bearings, type	5, replaceable inserts	
Valve material		
Intake	Chrome/silicone steel	
Exhaust	Stellite F	
Piston material	High silicon content aluminum	
Governor, type	Electronic	

Engine Electrical

Engine Electrical System	60 Hz	50 Hz
Ignition	Electronic, distributorless	
Starter motor	Solenoid-actuated pinion	
Spark plugs	Resistor-type RFI suppression	
Battery voltage (DC)	12	
Battery charging alternator	70 amp	
Battery recommendation (min.)	600 CCA @ -18°C (0°F)	

Fuel

Fuel System	60 Hz	50 Hz
Type	Port fuel injected	
Fuel pump	Electric	
Fuel pump, max. lift, m (ft.)	0.9 (3.0)	

Fuel Consumption	60 Hz	50 Hz
Gasoline, Lph (gph) at % load		
100%	6.9 (1.8)	5.3 (1.4)
75%	5.7 (1.5)	4.4 (1.1)
50%	4.2 (1.1)	3.5 (0.9)
25%	2.9 (0.8)	2.6 (0.7)

Lubrication

Lubricating System	60 Hz	50 Hz
Type	Pressure, eccentric bi-rotor	
Oil capacity with filter, L (qts.)	3.5 (3.7)	

Cooling

Cooling System	60 Hz	50 Hz
L (qts.)	7.6 (8.0)	
Heat exchanger type	3.0 in. dia. x 3 pass cupro-nickel	
Seawater pump type	Belt driven	
Heat rejected to cooling water at rated kW, wet exhaust Btu/min.	1567	1493
Engine water pump flow, Lpm (gpm)	37.9 (10.0)	31.4 (8.3)
Seawater pump flow, Lpm (gpm)	33.3 (8.8)	27.8 (7.3)

Operation Requirements

Air Requirements (Engine)	60 Hz	50 Hz
Engine combustion air requirements m ³ /min. (cfm)	1.13 (40)	0.9 (30.8)
Generator cooling requirements m ³ /min. (cfm)	5.9 (210)	

Engine Features

- Meets Coast Guard safety standards for electrical systems and gasoline fuel systems (33CFR183)
- One-side serviceability of fuel system, lubrication system, seawater pump, and air intake silencer/backfire flame arrestor
- Low oil pressure cutout
- High water and high exhaust temperature cutouts
- Vibromounts
- Plastic belt guard
- Disposable oil filter
- Fuel filter
- Oil drain petcock with extension hose
- Belt tensioner

Generator Features

- Static excited, rotating field design permits power to be obtained from stationary leads.
- Rotor and stator are vacuum impregnated and coated with high-bond epoxy varnish. Varnish helps prevent corrosion in high-humidity areas.
- Rotors are dynamically balanced to minimize vibration.
- Copper windings ensure minimal heat buildup. Insulation meets NEMA standards for class H insulation.
- Directly connected to the engine, the generator has sealed precision ball bearings with a precision-machined steel sleeve in the end bracket (or end bearing tolerance ring) to prevent shaft misalignment and extend bearing life.
- Circuit breakers protect the generator from extreme overload.
- Mounted on a drip-proof tray.
- Equipped with a four-lead reconnectable stator.

Application Data

ADC 2100 Control Features

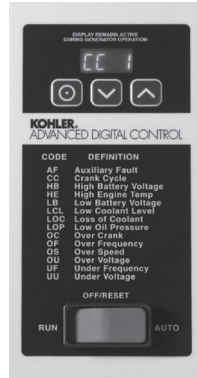

- LED display:
 - Runtime hours
 - Crank cycle status
 - Diagnostics/fault codes/data
- Keypad
 - Secure access, password protected
 - Voltage, gain, and speed adjustment
 - Controller configuration (system voltage, phase, and frequency settings, battery voltage, and generator set model)
- Master control switch: run/off-reset/auto (engine start)
- Remote two-wire start/stop capability
- Potted electronics and sealed connections
- Voltage regulation $\pm 1.5\%$
- Cyclic cranking: 15 seconds on, 15 seconds off (3 cycles)
- Faults with shutdown:
 - High engine temperature
 - Low oil pressure
 - Loss of coolant
 - Overcrank safety
 - Overspeed
 - Over/under voltage
 - Over/under frequency
 - Auxiliary fault
 - Carbon monoxide
- Faults with warning:
 - Low battery voltage
 - High battery voltage
 - Carbon monoxide
- Power requirements:
 - 12 VDC with fuse protection
 - 200 mA @ 12VDC

Accessories

Siphon Break

Mandatory kit for generators installed below the waterline. Prevents the siphoning of flotation water into the engine.

Ship-to-Shore Switch

The Kohler ship-to-shore transfer switch allows immediate switching to the Kohler® generator set power or shore power, protecting the electrical system from the possibility of simultaneous connection to both power sources.

Remote Digital Gauge

Allows starting/stopping from a location remote from the generator set. Standard 76.2 (3 in.) dia. hole required for mounting.

Oil Pressure and Water Temperature Sender Kit

Provides the senders necessary to display oil pressure and water temperature on the digital gauge.

Remote Start Panel

Allows starting/stopping from a location remote from the generator set. Supplied with a 101 mm (4 in.) connection harness. The overall mounting dimensions are 128 mm (5.04 in.) by 70 mm (2.76 in.) with a minimum mounting depth of 57 mm (2 1/4 in.).

Remote Connection/Extension Harness

Provides wiring between the remote digital gauge and the ADC connector. Extension limited to a total of four kits and 23 m (75 ft.). Available in 4.6 m (15 ft.) and 7.6 m (25 ft.) lengths.

12-Inch Remote Wiring Harness

Equipped with a 12-pin connector on one end that connects to the standard customer interface connector. Equipped on the other end with leads for connection to customer-supplied wiring.

Line Circuit Breakers

Protects the generator from extreme overload.

Sea Spares™ Maintenance Kit

Kohler's Sea Spares Kit consists of a durable white utility box filled with necessary marine parts.

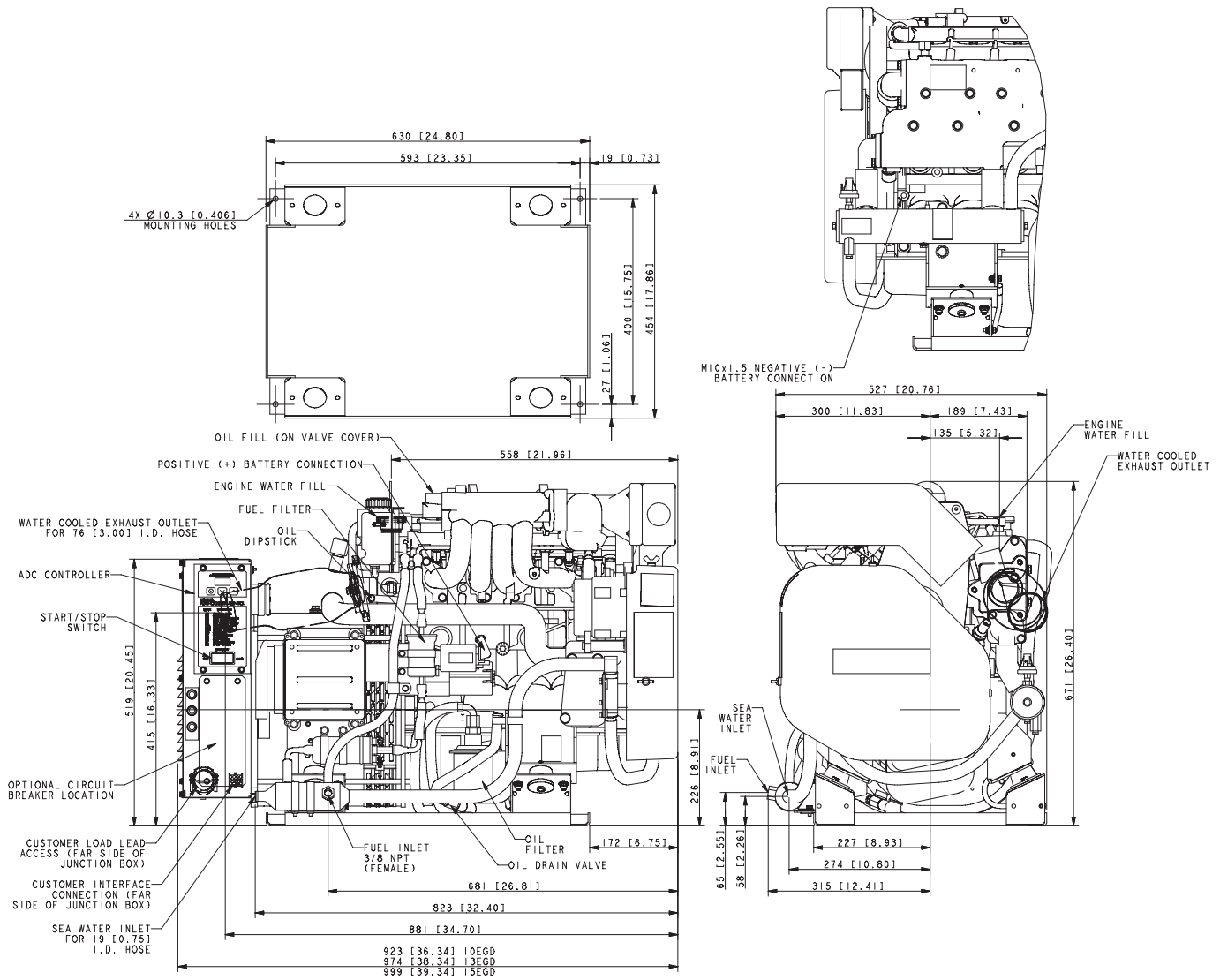

ADV-7278A-

DISTRIBUTED BY:

NOTE: Dimensions in brackets are inch equivalents.

NOTE: This drawing is provided for reference only and is not intended for installation planning. Contact your local distributor for more detailed information.

© 2006 by Kohler Co. All rights reserved.