

**Model: 10EOZD 60 Hz**  
**9EFOZD 50 Hz**

# KOHLER POWER SYSTEMS

**1-Phase Diesel**

**ISO 9001**  
**KOHLER**  
**POWER SYSTEMS**  
NATIONALLY REGISTERED

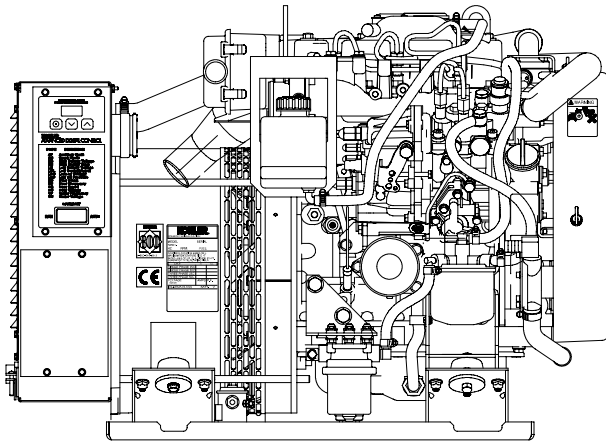

## Marine Generator Set

### Engine Features

- Diesel fueled
- Three cylinder
- Four cycle
- Closed cooling system
- Heat exchanger
- Electric fuel lift pump
- Lifting eyes

### Generator Features

- Remote start 12-pin connector
- Class H insulation
- Multivoltage adjustability
- 60/50 Hz capability
- Voltage regulation of  $\pm 1.5\%$
- Radio suppression

## Generator Weights and Dimensions

	Without Sound Shield	With Sound Shield
Weight, kg (lb.)		
Wet	263 (580)	310 (684)
Dry	259 (570)	306 (674)
Length, mm (in.)	850 (33.47)	934 (36.75)
Width, mm (in.)	520 (20.47)	578 (22.75)
Height, mm (in.)	617 (24.30)	664 (26.15)

## Generator Ratings

Model Series	Voltage	Hz	25° C (77° F)	25° C (77° F)	Ph
			Amps	kW/kVA	
10EOZD	120	60	83.3	10/10	1
	120/240	60	83.3/41.7	10/10	1
	115/230	50	78.3/39.1	9/9	1
9EFOZD	230	50	39.1	9/9	1
	240	50	37.5	9/9	1

RATINGS: Marine continuous ratings per ISO 3046, ISO 8528-1, and Kohler ISO rating guideline 2.14. Obtain technical information bulletin (TIB-101) on ratings guidelines for complete ratings definitions.

Availability is subject to change without notice. Kohler Co. reserves the right to change the design or specifications without notice and without any obligation or liability whatsoever. Contact your local Kohler generator distributor for availability.

10% Overload Capacity One Hour in Twelve Hours

## ADC 2100 Advanced Digital Control Features

- Designed for today's most sophisticated electronics
- Easy to read alpha-numeric display
- Compact, integrally mounted control
- Potted boards/sealed connectors for maximum corrosion protection
- SAE J-1939 CANbus output
- Remote monitoring of up to 13 fault conditions
- Membrane keypad for configuration and adjustment
- Programmed crank cycle

## Optional Accessories

- Sound shield
- Remote digital gauge
- Siphon break
- Circuit breakers

# Application Data

## Engine

Engine Specifications	60 Hz	50 Hz
Type	4 cycle	
Cylinder, quantity	3	
Displacement, L (cu. in.)	1.33 (81.14)	
Bore and stroke, mm (in.)	82 x 84 (3.23 x 3.30)	
Compression ratio	19.2:1	
Combustion system	Direct injection	
Rated rpm	1800	1500
Max. power at rated rpm, HP	18.4	15.1
Cylinder block material	Cast iron	
Cylinder head material	Cast iron	
Piston rings: quantity, type	2 compression/1 oil	
Crankshaft material	Forged steel	
Connecting rod material	Forged carbon steel	
Governor, type	Centrifugal, mechanical	
Frequency regulation, mechanical governor		
No load to full load (droop) . . . . .	±5%	
Steady state . . . . .	±0.8%	

## Engine Electrical

Engine Electrical System	60 Hz	50 Hz
Battery, voltage	12 volt (standard) 24 volt (optional)	
Battery, charging	40-amp alternator	
Battery, minimum recommendation	500 CCA, 100 amp hr.	
Starter motor	1.8 kW Bendix, gear-reduction automotive type	

## Cooling

Cooling System	60 Hz	50 Hz
Capacity, L (qt.), approx.	2.46 (2.6)	
Heat exchanger type	2.5 in. dia. x 3 pass cupronickel	
Seawater pump type	Belt-driven, 10-blade impeller	
Heat rejected to cooling water at rated kW, wet exhaust, kW (Btu/min.)	10.0 (574)	8.3 (472)
Engine water pump flow, Lpm (gpm)	32.4 (8.6)	27.0 (7.1)
Seawater pump flow, Lpm (gpm)	22.7 (6.0)	18.9 (5.0)

## Fuel

Fuel System	60 Hz	50 Hz
Fuel shutoff solenoid	Electric	
Fuel pump	Electric, rotary vane	
Fuel pump priming	Electric	
Maximum recommended fuel lift, m (ft.)	1.2 (4.0)	

## Lubrication

Lubricating System	60 Hz	50 Hz
Oil pan capacity with filter, L (qt.)	3.6 (3.8)	
Oil pump type	Pressure, trochoid pump	

## Operation Requirements

Air Requirements	60 Hz	50 Hz
Engine combustion air requirements, L/min. (cfm)	1080 (38.1)	900 (31.8)
Engine/generator cooling requirements, L/min. (cfm)	4814 (170)	3964 (140)

Fuel Consumption	60 Hz	50 Hz
<b>Diesel, Lph (gph) at % load</b>		
100%	4.0 (1.05)	2.5 (0.67)
75%	2.7 (0.72)	1.8 (0.47)
50%	2.0 (0.53)	1.7 (0.45)
25%	1.3 (0.35)	1.1 (0.30)

**Note:** The fuel consumption of the 60 Hz model is based on 10EOZD and the fuel consumption of the 50 Hz model is based on 9EFOZD.

## Sound Data

Sound Levels	60 Hz	50 Hz
Measured at 1 meter (3.28 ft.) with a housed generator set operating at full load, dBA	66	65

## Engine Features

- One-side serviceability of fuel system, lubrication system, seawater pump, and air cleaner
- Low oil pressure shutdown
- High engine temperature shutdown
- Loss of coolant shutdown
- Seawater pump impeller failure shutdown
- Focused vibromounts
- Belt guard
- Disposable oil filter
- Oil drain valve and hose
- Full flow cooling system (thermostat bypass)
- Air intake heater circuit for cold starting (optional)

## Generator Features

- Brushless, rotating field design permits power to be obtained from stationary leads.
- Rotor and stator are vacuum impregnated and coated with high-bond epoxy varnish. Varnish helps prevent corrosion in high-humidity areas.
- Rotors are dynamically balanced to minimize vibration.
- Copper windings ensure minimal heat buildup. Insulation meets NEMA standards for class H insulation.
- Direct connected to the engine, the generator has sealed precision ball bearings with a precision-machined steel sleeve in the end bracket to prevent shaft misalignment and extend bearing life.
- Mounted on a drip-proof tray.
- Equipped with a four-lead reconnectable stator.

# Application Data

## ADC 2100 Control Features



- LED display:
  - Runtime hours
  - Crank cycle status
  - Diagnostics/fault codes/data
- Keypad
  - Secure access, password protected
  - Voltage, gain, and speed adjustment
  - Controller configuration (system voltage, phase, and frequency settings, battery voltage, and generator set model)
- Master control switch: run/off-reset/auto (engine start)
- Remote two-wire start/stop capability
- Potted electronics and sealed connections
- Voltage regulation  $\pm 1.5\%$
- Cyclic cranking: 15 seconds on, 15 seconds off (3 cycles)
- Faults with shutdown:
  - High engine temperature
  - Low oil pressure
  - Loss of coolant
  - Overcrank safety
  - Overspeed
  - Over/under voltage
  - Over/under frequency
  - Auxiliary fault
- Faults with warning:
  - Low battery voltage
  - High battery voltage
- Power requirements:
  - 12 or 24 VDC with fuse protection
  - 200 mA @ 12VDC/100 mA @ 24 VDC

## Accessories

### Sound Shield

Provides for highly effective silencing, ease of access for engine/generator servicing, low maintenance, excellent durability, and safety. The sound shield's customer connection panel includes connections for the following:

- Battery (positive and negative)
- Equipment ground
- Fuel inlet and return
- Seawater inlet
- Water-cooled exhaust outlet
- Oil drain
- Customer load lead access
- Customer interface

### Siphon Break

Mandatory kit on generators installed below the waterline. Prevents the siphoning of flotation water into the engine.

### Line Circuit Breakers

Protect the generator from extreme overload.

### Preheat Kit

Provides improved starting in cold climates.

### Ship-to-Shore Switch

Allows immediate switching to Kohler® generator set power or shore power protecting the electrical system from the possibility of simultaneous connection of both power sources. Available as a three-pole ship-to-shore switch.

### Remote Digital Gauge

Allows starting/stopping from a location remote from the generator set. Standard 76.2 mm (3 in.) dia. hole required for mounting.

### Oil Pressure Sender Kit

Provides sender necessary to make digital gauge functional.

### Remote Connection/Extension Harness

Provides wiring between the remote digital gauge and the ADC connector. Extension limited to a total of four kits and 23 m (75 ft.). Available in 4.6 m (15 ft.) and 7.6 m (25 ft.) lengths.

### 12-Inch Remote Wiring Harness

Equipped with a 12-pin connector on one end that connects to the standard customer interface connector. Equipped on the other end with leads for connection to customer-supplied wiring.

# KOHLER POWER SYSTEMS

KOHLER CO., Kohler, Wisconsin 53044 USA  
 Phone 920-565-3381, Fax 920-459-1646  
 For the nearest sales and service outlet in the  
 US and Canada, phone 1-800-544-2444  
 KohlerPowerSystems.com

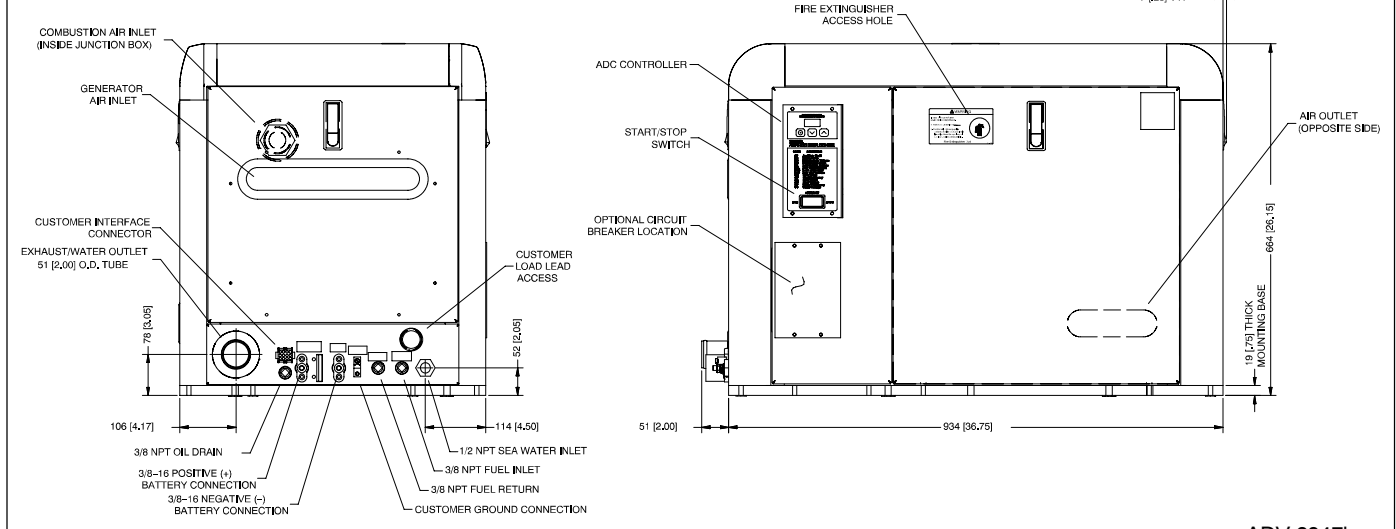
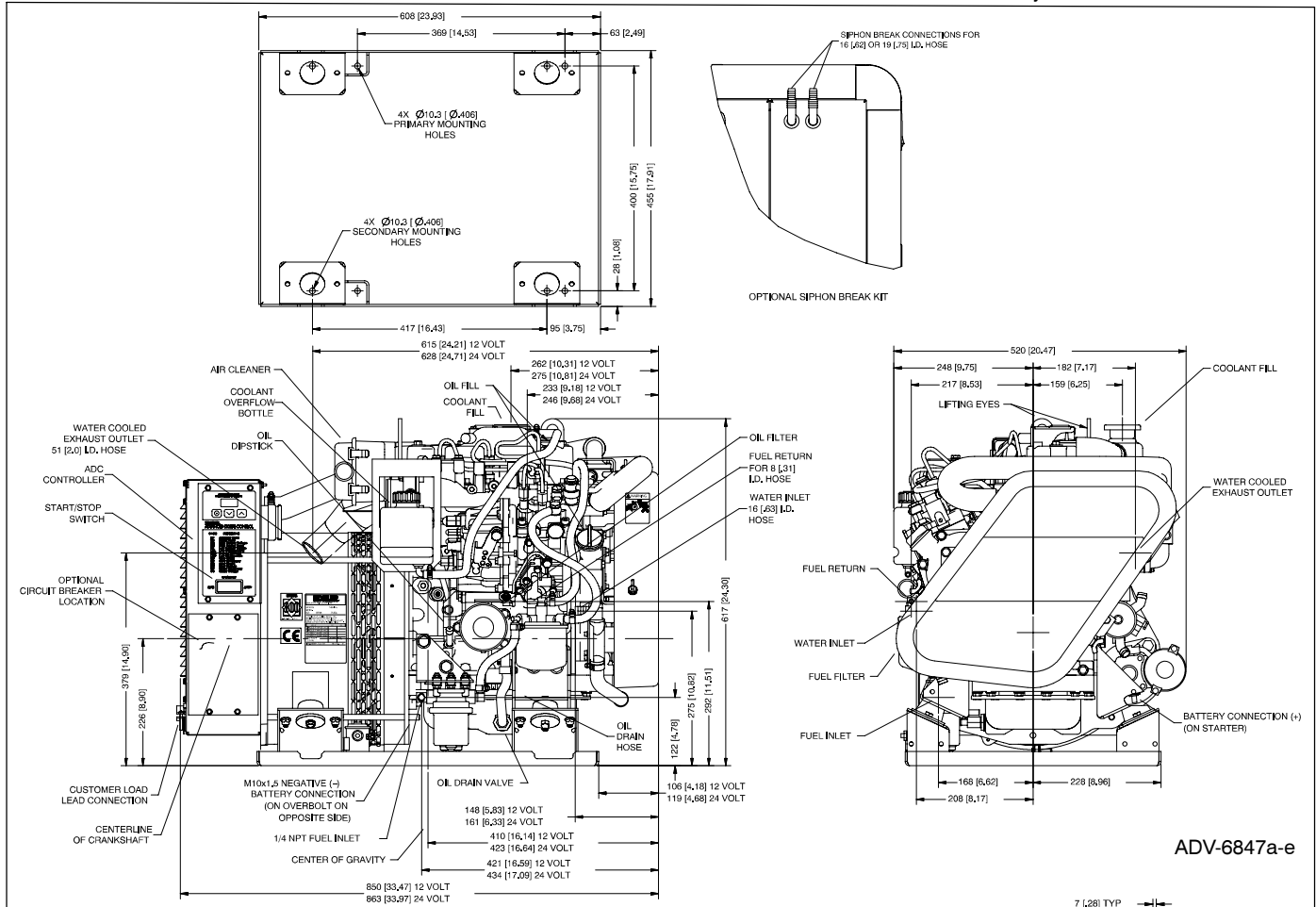

NOTE: Dimensions in [ ] are inch equivalents.

NOTE: This drawing is provided for reference only and is not intended for installation planning. Contact your local distributor for more detailed information.

© 2003, 2004, 2005, and 2006 by Kohler Co. All rights reserved.

**DISTRIBUTED BY:**