

# VOLVO PENTA INBOARD DIESEL

# D2-55

41 kW (55 hp) crankshaft power acc. to ISO 8665

## D2-55 – a new standard for yacht comfort

The Volvo Penta D2-55 marine diesel delivers 55 hp with exceptional comfort. Low cruising rpm gives quiet running and low vibrations, and exhaust emissions are extremely low. Compact size means easy installation, and the 115 A alternator with a built-in charging sensor provides rapid charging for onboard electrical needs. Setting a new standard for yacht comfort.

The D2-55 is a marine engine of advanced design manufactured from quality components and designed to fulfil customer requirements.

### Service Life

The D2-55 is fitted with fresh-water cooling as standard. This reduces internal corrosion and enables the engine to maintain a consistent and optimal working temperature under all conditions.

To avoid galvanic corrosion the engine is equipped with the unique electrical isolation between engine and S-drive.

### Comfort

Smooth running with very low vibration levels results from a dynamically balanced design incorporating a flywheel of high rotating mass and high efficiency rubber isolation.

The engine's high torque provides excellent operating characteristics to aid maneuvering, particularly in confined spaces.

Additional on board comfort features are available from an extensive range of matched accessories.

### Charging capacity

The new 115A alternator with an electronic sensor makes it possible to use a higher battery capacity and have fully charged batteries on board. Even at idle speed, the alternator gives more than 35A, and at cruising speed it delivers approx. 100A.

### Transmissions

Eight matched transmission options are available, each built for durability and smooth running.

### Environment

An advanced combustion system increases fuel burning efficiency to minimize noxious exhaust emissions and enhance overall enjoyment of boating. The D2-55 complies with BSO II, SAV and the comprehensive emission requirements being introduced in Europe in 2006 and in the US in 2007.

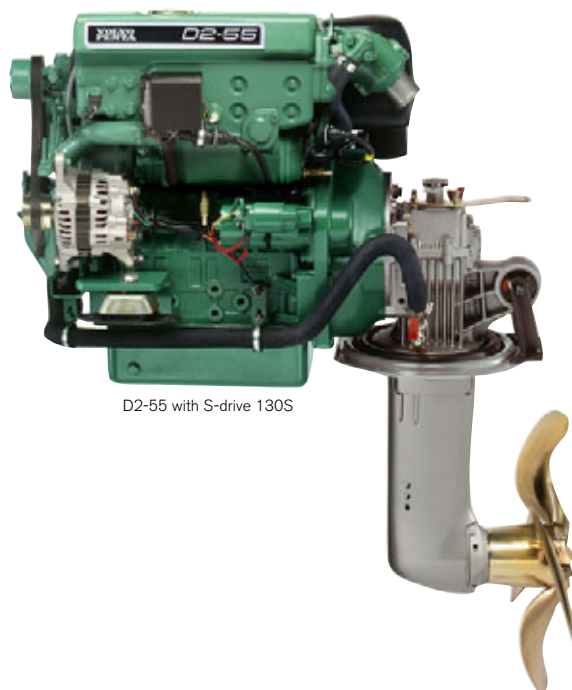

D2-55 with S-drive 130S

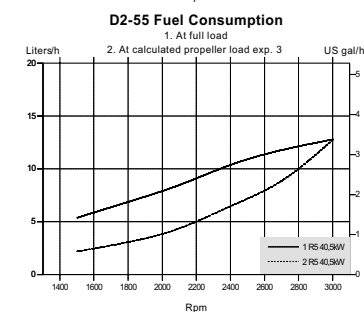
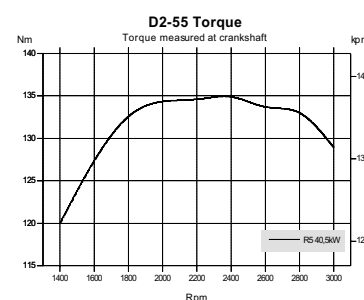
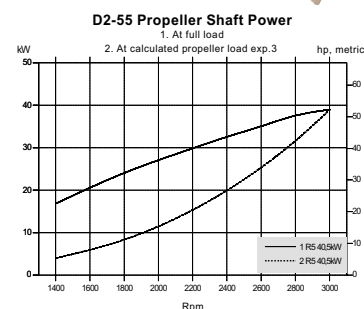

**VOLVO  
PENTA**

# D2-55

## Technical description:

### Engine block and head

- Cylinder block and cylinder head manufactured from high grade cast iron. Crankcase features a rigid tunnel block design.
- Chrome molybdenum forged crankshaft, statically and dynamically balanced with integral counterweights. Pistons are cast from high silicon aluminum, are heat treated and fitted with two cast iron, chromium faced compression rings and a single oil ring.
- Replaceable, hardened valve seats
- Elastic coupling on flywheel

### Engine mounting

- Tuned front and rear cushion-type rubber mounts. Adjustable.

### Lubrication system

- Spin-on fullflow oil filter
- Separate oil scavenger pipe
- Closed circuit crankcase ventilation

### Fuel system

- Flange mounted, cam driven in-line injection pump
- Feed pump with hand primer
- Spin-on type fine fuel filter

### Exhaust system

- Freshwater cooled exhaust manifold and

seawater cooled exhaust elbow

### Cooling system

- Freshwater cooling system governed by thermostat
- Tubular heat exchanger with integral expansion tank
- Coolant system prepared for hot water outlet fittings
- Easily accessible sea water pump and impeller

### Electrical system

- 12V corrosion-protected electrical system
- 115A marine alternator
- Charging regulator with electronic sensor for voltage drop compensation
- Glow plugs for excellent cold starting
- Electric starter motor (2.0 kW output)
- Electrical stop
- Extension cable harness with plug-in connection available in various lengths

### Choice of instrument panel:

- Standard panel, including:
- Optional rev counter incl. hour counter
  - Start button or key switch
  - Alarm (for monitoring temperature, oil pressure and charge rate)
  - Instrument panel lighting
  - Switch for alarm test and glow

De Luxe panel including:

- Optional rev counter incl. hour counter
- Key switch
- Temperature gauge
- Oil pressure gauge
- Voltmeter
- Alarm (for monitoring temperature, oil pressure and charge rate)
- Instrument panel lighting
- Alarm test button

### Choice of transmissions:

**HS25A** Hydraulic – drop center with 8° down angled output shaft. Trolling valve kit available.

- Ratio 2.29:1/2.29:1 (RH/LH) and 2.71:1/2.71:1 (RH/LH).

**MS25A** Mechanical – drop center with 8° down angled output shaft.

- Ratio 2.23:1/2.74:1 (RH/LH) and 2.74:1/2.74:1 (RH/LH).

**MS25L** Mechanical – drop center with straight output shaft.

- Ratio 2.27:1/2.10:1 (RH/LH) and 2.74:1/2.72:1 (RH/LH).

**S-drive 130S and 130SR** for reverse installation of engine. Ratio 2.19:1.

### Accessories

- Engine controls and steering systems
- Additional instrument panels and instruments
- Extra alternator kits
- Battery and battery switches
- Hot water systems
- Separate expansion tanks
- Cooling water seacocks, strainers and hoses
- Exhaust systems and hull fittings
- Fuel systems including filters, pipes etc.
- Pulleys and universal brackets for power take-off (PTO)
- Propeller shaft systems and propellers
- Chemical products – paints, oils, cleaners etc.

Contact your local Volvo Penta dealer for further information.

Not all models, standard equipment and accessories are available in all countries. All specifications are subject to change without notice.

The engine illustrated may not be entirely identical to production standard engines.

## Technical Data

|                                          |                    |
|------------------------------------------|--------------------|
| Engine designation .....                 | <b>D2-55</b>       |
| Crankshaft power, kW (hp) .....          | 41 (55)            |
| Propeller shaft power, kW (hp) .....     | 39 (53)            |
| Engine speed, rpm .....                  | 3000               |
| Displacement, l (in <sup>3</sup> ) ..... | 2.2 (134.2)        |
| Number of cylinders .....                | 4                  |
| Bore/stroke, mm (in.) .....              | 84/100 (3.31/3.94) |
| Compression ratio .....                  | 23.3:1             |
| Dry weight with                          |                    |
| reverse gear HS25A/MS25, kg (lb) .....   | 249/243 (549/536)  |
| sail drive 130S/SR, kg (lb) .....        | 253 (558)          |

Duty rating: R5

Technical data according to ISO 8665. With fuel having an LHV of 42,700 kJ/kg and density of 840 g/liter at 15°C (60°F). Merchant fuel may differ from this specification which will influence engine power output and fuel consumption.

The engine complies with BSOII, SAV and the comprehensive emission requirements being introduced in Europe in 2006 and in the US in 2007.

## Dimensions D2-55/MS25A/130S (mm)

Not for installation

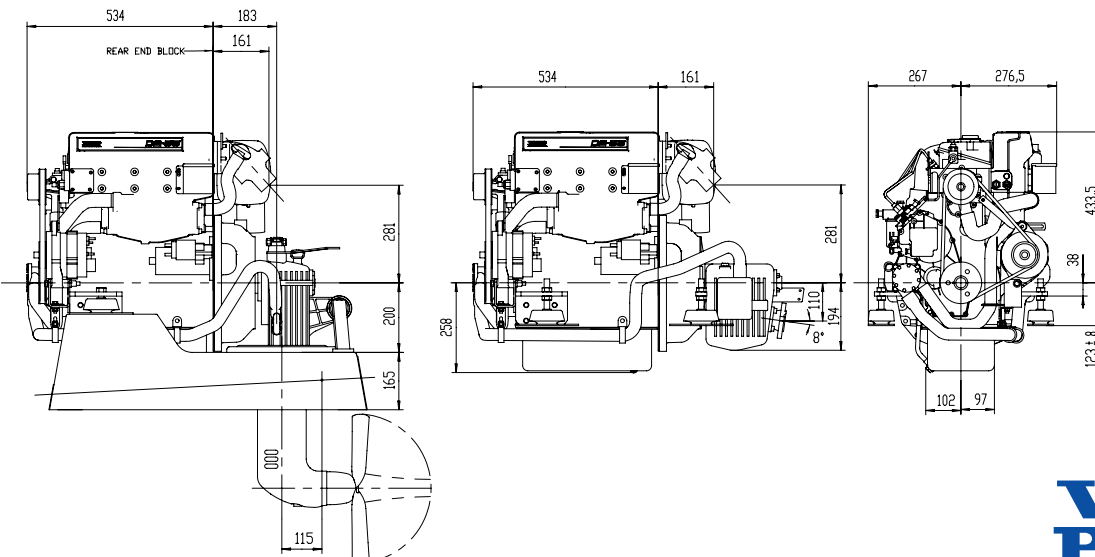

# VOLVO PENTA

**AB Volvo Penta**  
SE-405 08 Göteborg, Sweden  
www.volvopenta.com