

# VOLVO PENTA INBOARD DIESEL

# D12-715

6-cylinder, 4-stroke, direct-injected, turbocharged marine diesel engine with aftercooler – crankshaft power\* 526 kW (715 hp)

\* Power rating – see Technical Data

## Excellent Performance and Cruising Range

The D12-715 marine diesel engine is specially designed and developed for installations in fast planing craft featuring the latest advanced diesel technology.

Excellent performance is assured with a rich torque curve matched to the high power output for quick out of the hole acceleration and high top and cruising speed.

Low fuel consumption for long cruising range and low emission levels is assured with:

- Electronic Unit Injectors
- 4-valve technology
- Electronically controlled injection timing
- High pressure 8-hole injector nozzles
- EDC governing

This technology combined optimizes engine performance and efficiency, ensures efficient combustion by injecting the right quantity of fuel at the right time, which minimizes quantity of unburned fuel, reducing fuel consumption and exhaust emission levels. The Volvo Penta D12-715 fuel system is designed to give full output regardless of fuel temperature.

This technology, in combination with the high power output, gives the boat a wider operating range in combination with higher speed.

## High quality

The D12-715 is built in the world's most highly automated diesel engine factory line with a totally robotic machining and assembly line with computer controlled audit checks, which ensures the highest quality level.

The D12-715 is a further development of the well-proven Volvo Penta in-line six engine concept which ensures high reliability and long term durability.

## Operation and comfort

Electronic remote controls, push button twin engine synchronization and change of active station ensures easy and smooth operation and maneuvering.

The electrical control levers are operated more smoothly and precisely, requiring much less force.



Automatic twin engine synchronization reduces noise and vibration levels, and increases service life of engine.

This in combination with the well-balanced D12-715 in-line six cylinder engine with powerfully dimensioned crankshaft bearings and vibration damper on camshaft ensures smooth, vibration-free operation with low noise levels.

## Low exhaust emission levels

The D12-715 advanced diesel technology greatly contributes to more efficient combustion with higher power and reduced noxious exhaust emissions.

The D12-715 is certified according to IMO.

## Easy installation

The D12-715 gives a time saving and reliable installation, as it is a complete delivered compact and tailor-made propulsion system from one single supplier.

Plug-in water-protected harnesses and connectors, compact dimensions and the EDC system ensures an easy, simple and time-saving installation.

## Ease of service and maintenance

The EDC system features a self-diagnostic facility. Easily accessible service

and maintenance points contributes to the ease of service of the engine.

## Worldwide service support in more than 100 countries

The Volvo Penta parts and service dealer network is a truly international operation with authorized service dealers around the world. These service centers offer Genuine Volvo Penta parts as well as skilled personnel to ensure the best possible service. Continuous and thorough product and service training ensures that Volvo Penta products are well supported.

## D12-715 – a true marine engine from a true marine engine company

The D12-715 is a true marine engine as it is developed by a true marine company with the best there is to be found in marine experience and know-how, and built and assembled with the best production method there is to be found in the world.

The D12-715 delivers excellent performance and cruising range, high reliability and durability, in combination with the highest level of quality.

**VOLVO  
PENTA**

# D12-715

## Technical Data

Engine designation ..... **D12-715**  
 No. of cylinders and configuration ..... in-line 6  
 Method of operation ..... 4-stroke,  
 direct-injected, turbocharged  
 diesel engine with aftercooler  
 Bore, mm (in.) ..... 131 (5.16)  
 Stroke, mm (in.) ..... 150 (5.91)  
 Displacement, l (in<sup>3</sup>) ..... 12.13 (740.2)  
 Compression ratio ..... 16.5:1  
 Dry weight, kg (lb) ..... 1400 (3086)  
 Dry weight with reverse gear  
 ZF 325A-EB, kg (lb) ..... 1570 (3461)  
 Crankshaft power,  
 kW (hp) @ 2300 rpm ..... 526 (715)  
 Max. torque,  
 Nm (lb.ft) @ 1600 rpm ..... 2925 (2159)  
 Recommended fuel to  
 conform to ..... ASTM-D975 1-D & 2-D,  
 ..... EN 590 or JIS KK 2204  
 Specific fuel consumption,  
 g/kWh (lb/hph) @ 2300 rpm ..... 228 (0.369)

Technical data according to ISO 3046 Fuel Stop Power and ISO 8665. Fuel with a lower calorific value of 42700 kJ/kg and density of 840 g/liter at 15°C (60°F). Merchant fuel may differ from this specification which will influence engine power output and fuel consumption.

Rating: 5  
 The engine is certified according to IMO.

## Technical description:

### Engine and block

- Cylinder block and cylinder head made of cast-iron
- One piece cylinder head
- Replaceable wet cylinder liners and valve seats/guides
- Drop forged crankshaft with induction hardened bearing surfaces and fillets with seven main bearings

- Four valve per cylinder layout with overhead camshaft
- Each cylinder features cross-flow inlet and exhaust ducts
- Gallery oil-cooled forged aluminum pistons
- Three piston rings

### Lubrication system

- Integrated oil cooler in cylinder block
- Twin full flow oil filter of spin-on type and by-pass filter

### Fuel system

- Six Electronic Unit Injectors, one per cylinder, vertically positioned at the center in between the four valves
- Gear-driven fuel pump, driven by timing gear
- Electronically controlled central processing system (EDC – Electronic Diesel Control)
- Electronically controlled injection timing
- 8-hole high pressure injector nozzles
- Single fine fuel filter of spin-on type, with water separator

### Turbocharger

- Freshwater-cooled turbo charger

### Cooling system

- Freshwater-cooled charge air cooler
- Gear-driven coolant pumps
- Tubular heat exchanger or single-circuit keel cooling

### Electrical system

- 24V electrical system, 24V/60A alternator

### Reverse gear

- ZF 325A-EB, electrically shifted

### Optional equipment

Contact your Volvo Penta representative.

Not all models, standard equipment and accessories are available in all countries. All specifications are subject to change without notice.

The engine illustrated may not be entirely identical to production standard engines.

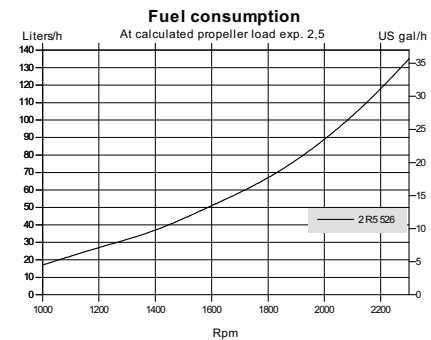
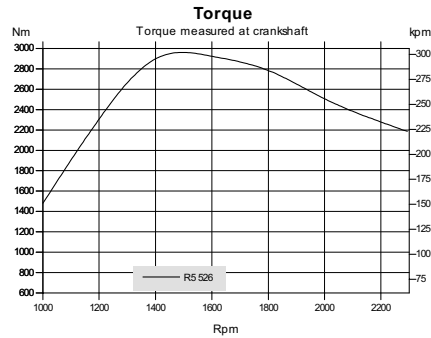
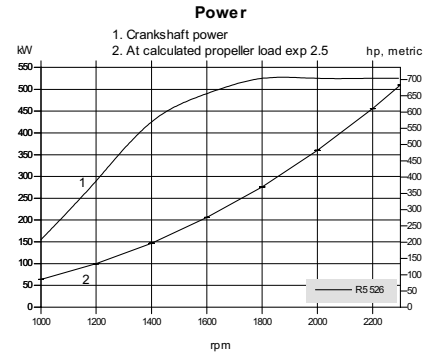

## Dimensions D12-715 with ZF 325A-EB

Not for installation

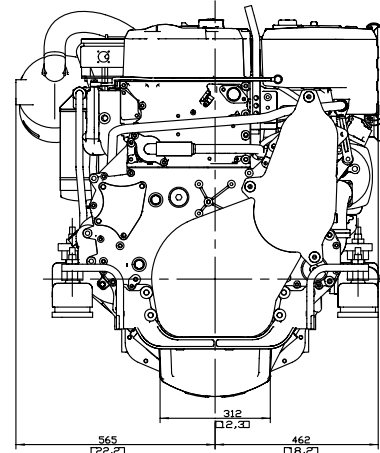
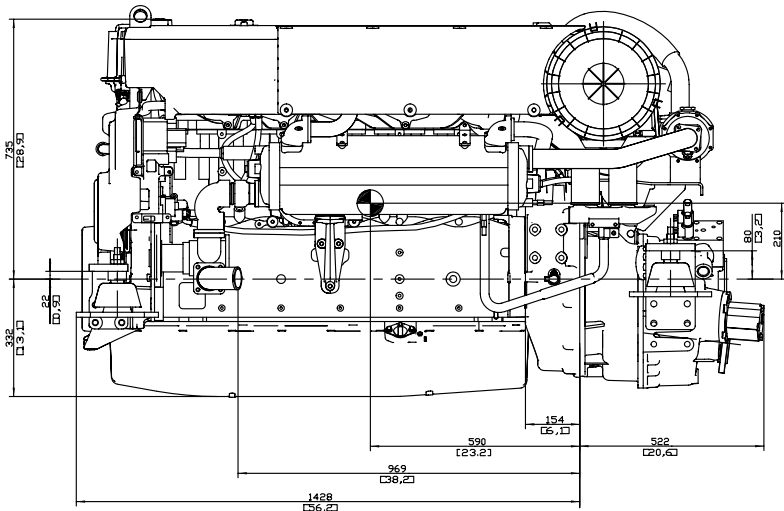

# VOLVO PENTA

**AB Volvo Penta**  
 SE-405 08 Göteborg, Sweden  
[www.volvopenta.com](http://www.volvopenta.com)